

DYB

SHIELDED BELT PRESS

- Optimized structure, reliable dewatering performance
- With removable full-body shield, easy for maintenance and odor treatment
- Compact design with full function, save your land and money
- Water ratio can be up to 98%



DIMENSION

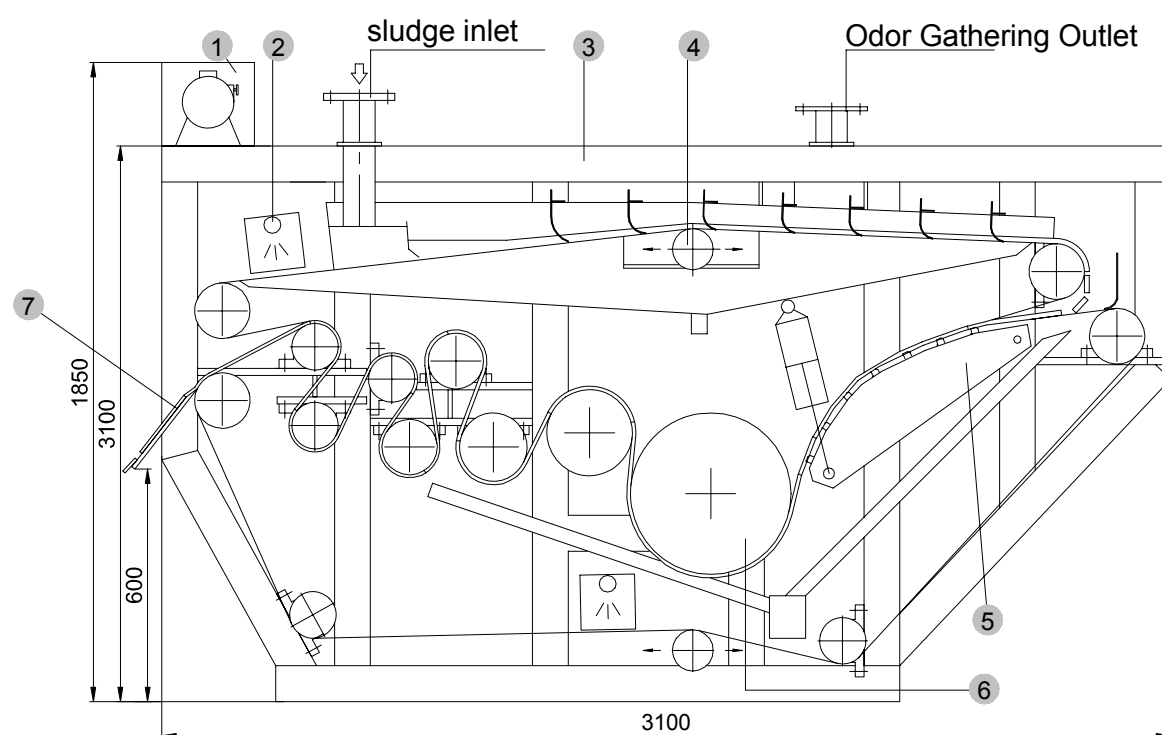

- LEGEND**
- 1 Motor
 - 2 Backwash Nozzle
 - 3 Frame
 - 4 Tracking System
 - 5 Belt Tension System
 - 6 Roller
 - 7 Scrapers

SPECIFICATION

Model	Unit	DYB600	DYB1000	DYB1500	DYB2000	DYB2500
Belt Width	mm	600	1000	1500	2000	2500
Belt Speed	m/min	1.0~5.0				
Motor Power (kW)	kw	1.1	1.1	1.5	1.5	2.2
Backwash Water Pressure	MPa	3~5	6~10	9~15	12~20	15~25
Backwash Water Flux	m ³ /h	≥0.5				
Net Weight	kg	2500	3500	4500	5500	7000
Loaded Weight	kg	2800	4000	5250	6500	8250
Dimensions (Length×Width×Height)	mm	32500X1110X1850	3250X1510X1850	3250X2010X1850	3250X2510X1850	3250X3010X1850

FOUNDATION REQUIREMENTS

Model	DYB600	DYB1000	DYB1500	DYB2000	DYB2500
Sludge Inlet D1	DN65	DN80	DN80	DN100	DN100
Backwash Water Inlet D2	DN32	DN32	DN32	DN32	DN32
Filtrate Outlet D3	DN100	DN150	DN150	DN200	DN200
Odor Gathering Outlet D4	DN100	DN150	DN150	DN200	DN200
Load F (N)	7000	10000	13500	16500	21000